

Air Compressor & Hopper Guns (Gravity-Fed & Pressurized)

3A5725A
EN

*For spray application of water-based architectural and texture coatings.
Air compressor for supplying air to hopper guns only.
Not approved for use in explosive atmospheres or hazardous (classified) locations.
For professional use only.*

See page 3 for model information.

*5 psi (0.03 MPa, 0.3 bar) Hopper Maximum Working Air Pressure
60 psi (0.41 MPa, 4.1 bar) Compressor Maximum Working Air Pressure
150 psi (1.03 MPa, 10.3 bar) Gun Maximum Working Air Pressure*



Important Safety Instructions

Read all warnings and instructions in this manual. Be familiar with the controls and the proper usage of the equipment. Save these instructions.

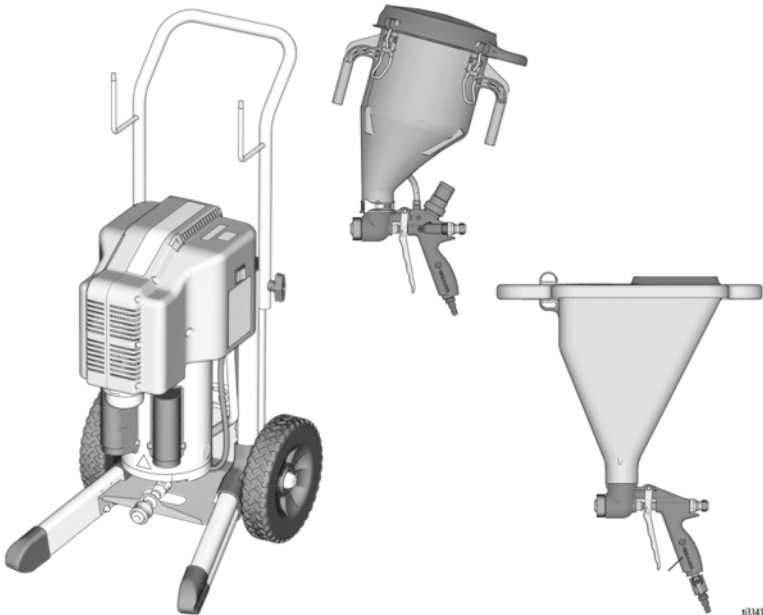



133411a

Table of Contents

Table of Contents

Models	3
Warnings	4
Component Identification	7
25D496 - Pressurized Hopper Gun	7
Component Identification	8
25D497 - Gravity-Fed Hopper Gun	8
Component Identification	9
25D490 - Air Compressor	9
Preparation	10
Pressure Relief Procedure	10
Grounding	11
Power Supply	11
Extension Cords	11
Setup	12
Material Hopper	12
Mixing Material	14
Operation (Pressurized Hopper Gun)	15
Texture Spraying	15
Adjusting the System (Pressurized Gun Only)	16
Cleanup	17
Troubleshooting	18
Parts - Air Compressor	20
25D490 (120V) & 25D491 (230V)	20
Parts List - Air Compressor	21
25D490 (120V) & 25D491 (230V)	21
Parts - Air Compressor (cont.)	22
25D490 (120V) & 25D491 (230V)	22
Parts List - Air Compressor (cont.)	23
25D490 (120V) & 25D491 (230V)	23
Parts - Air Compressor	24
25D490 (120V) & 25D491 (230V)	24
Parts List - Air Compressor	25
25D490 (120V) & 25D491 (230V)	25
Parts - Pressurized Hopper 25D496	26
Parts List- Pressurized Hopper 25D496	27
Parts - Pressurized Gun 25D496	28
Parts List - Pressurized Gun 25D496	29
Parts - Gravity-Fed Hopper Gun 25D497	30
Parts List - Gravity-Fed Hopper Gun 25D497	31
Wiring Diagram	32
Air Diagram	32
Technical Specifications	33
Graco Standard Warranty	34
Graco Information	35

Models

	Model	Description	VAC
	25D490	Air Compressor, bare	120 USA
	25D492	Air Compressor, w/ pressurized hopper gun	
	25D494	Air Compressor, w/ gravity-fed hopper gun	
	25D491	Air Compressor, bare	230 Europe
	25D493	Air Compressor, w/ pressurized hopper gun	
	25D495	Air Compressor, w/ gravity-fed hopper gun	
	25D496	Pressurized Hopper Gun	
	25D497	Gravity-Fed Hopper Gun	

Warnings

The following warnings are for the setup, use, grounding, maintenance, and repair of this equipment. The exclamation point symbol alerts you to a general warning and the hazard symbols refer to procedure-specific risks. When these symbols appear in the body of this manual or on warning labels, refer back to these Warnings. Product-specific hazard symbols and warnings not covered in this section may appear throughout the body of this manual where applicable.

WARNING



GROUNDING

This product must be grounded. In the event of an electrical short circuit, grounding reduces the risk of electric shock by providing an escape wire for the electric current. This product is equipped with a cord having a grounding wire with an appropriate grounding plug. The plug must be plugged into an outlet that is properly installed and grounded in accordance with all local codes and ordinances.

- Improper installation of the grounding plug is able to result in a risk of electric shock.
- When repair or replacement of the cord or plug is required, do not connect the grounding wire to either flat blade terminal.
- The wire with insulation having an outer surface that is green with or without yellow stripes is the grounding wire.
- Check with a qualified electrician or serviceman when the grounding instructions are not completely understood, or when in doubt as to whether the product is properly grounded.
- Do not modify the plug provided; if it does not fit the outlet, have the proper outlet installed by a qualified electrician.
- This product is for use on a nominal 120V or 230V circuit and has a grounding plug similar to the plugs illustrated below.

120V US

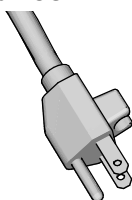

230V

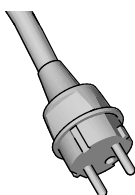

- Only connect the product to an outlet having the same configuration as the plug.
- Do not use an adapter with this product.

Extension Cords:

- Use only a 3-wire extension cord that has a grounding plug and a grounding receptacle that accepts the plug on the product.
- Make sure your extension cord is not damaged. If an extension cord is necessary use 12 AWG (2.5mm²) minimum, 50 ft maximum length, to carry the current that the product draws.
- An undersized cord results in a drop in line voltage and loss of power and overheating.

WARNING



ELECTRIC SHOCK HAZARD

This equipment must be grounded. Improper grounding, setup, or usage of the system can cause electric shock.

- Turn off and disconnect power cord before servicing equipment.
- Connect only to grounded electrical outlets.
- Use only 3-wire extension cords.
- Ensure ground prongs are intact on power and extension cords.
- Do not expose to rain. Store indoors.



PRESSURIZED EQUIPMENT HAZARD

Fluid from the equipment, leaks, or ruptured components can splash in the eyes or on skin and cause serious injury.

- Follow the **Pressure Relief Procedure** when you stop spraying/dispensing and before cleaning, checking, or servicing equipment.
- Tighten all fluid connections before operating the equipment.
- Check hoses, tubes, and couplings daily. Replace worn or damaged parts immediately.



EQUIPMENT MISUSE HAZARD

Misuse can cause death or serious injury.

- Always wear appropriate gloves, eye protection, and a respirator or mask when spraying.
- Do not operate or spray near children. Keep children away from equipment at all times.
- Do not overreach or stand on an unstable support. Keep effective footing and balance at all times.
- Stay alert and watch what you are doing.
- Do not operate the unit when fatigued or under the influence of drugs or alcohol.
- Do not kink or over-bend the hose.
- Do not expose the hose to temperatures or to pressures in excess of those specified by Graco.
- Do not use the hose as a strength member to pull or lift the equipment.
- Do not alter or modify equipment. Alterations or modifications may void agency approvals and create safety hazards.
- Make sure all equipment is rated and approved for the environment in which you are using it.

Warnings

WARNING

PLASTIC PARTS CLEANING SOLVENT HAZARD



Many cleaning solvents can degrade plastic parts and cause them to fail, which could cause serious injury or property damage.



- Use only compatible solvents to clean plastic structural or pressure-containing parts.
- See **Technical Specifications** in all equipment manuals for materials of construction. Consult the solvent manufacturer for information and recommendations about compatibility.

MOVING PARTS HAZARD



Moving parts can pinch, cut or amputate fingers and other body parts.



- Keep clear of moving parts.
- Do not operate equipment with protective guards or covers removed.
- Pressurized equipment can start without warning. Before checking, moving, or servicing equipment, follow the **Pressure Relief Procedure** and disconnect all power sources.

BURN HAZARD



Equipment surfaces and fluid that is heated can become very hot during operation.

- Do not touch hot fluid or equipment.

PERSONAL PROTECTIVE EQUIPMENT



Wear appropriate protective equipment when in the work area to help prevent serious injury, including eye injury, hearing loss, inhalation of toxic fumes, and burns. This protective equipment includes but is not limited to:

- Protective eyewear, and hearing protection.
- Respirators, protective clothing, and gloves as recommended by the fluid and solvent manufacturer.

CALIFORNIA PROPOSITION 65

This product contains a chemical known to the State of California to cause cancer, birth defects or other reproductive harm. Wash hands after handling.

Component Identification

25D496 - Pressurized Hopper Gun

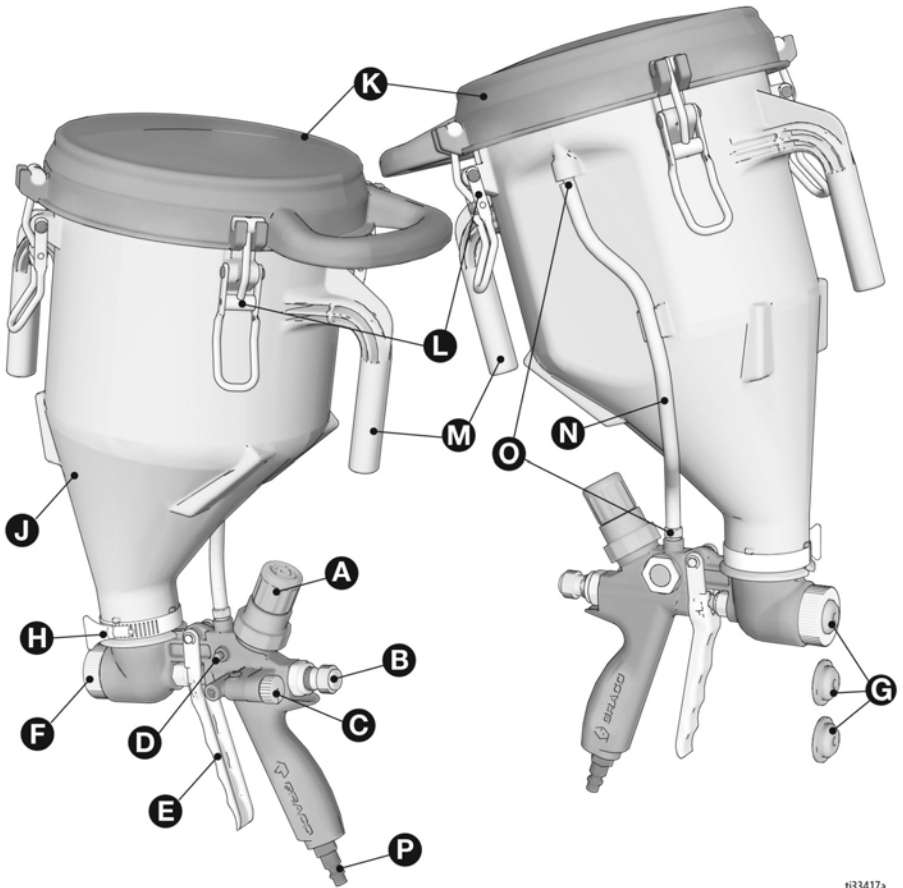

t133417a

A	Material Flow Regulator
B	Needle Travel Adjustment Knob
C	Air Flow Valve
D	Pressure Relief Valve
E	Trigger
F	Nozzle Retainer
G	Material Nozzles (4mm, 6mm & 8mm)
H	Hopper Clamp

J	Hopper
K	Hopper Lid
L	Lid Clamps
M	Hopper Handle
N	Hopper Air Supply Tube
O	Hopper Tube Barbs
P	Air Hose Fitting

Component Identification

Component Identification

25D497 - Gravity-Fed Hopper Gun

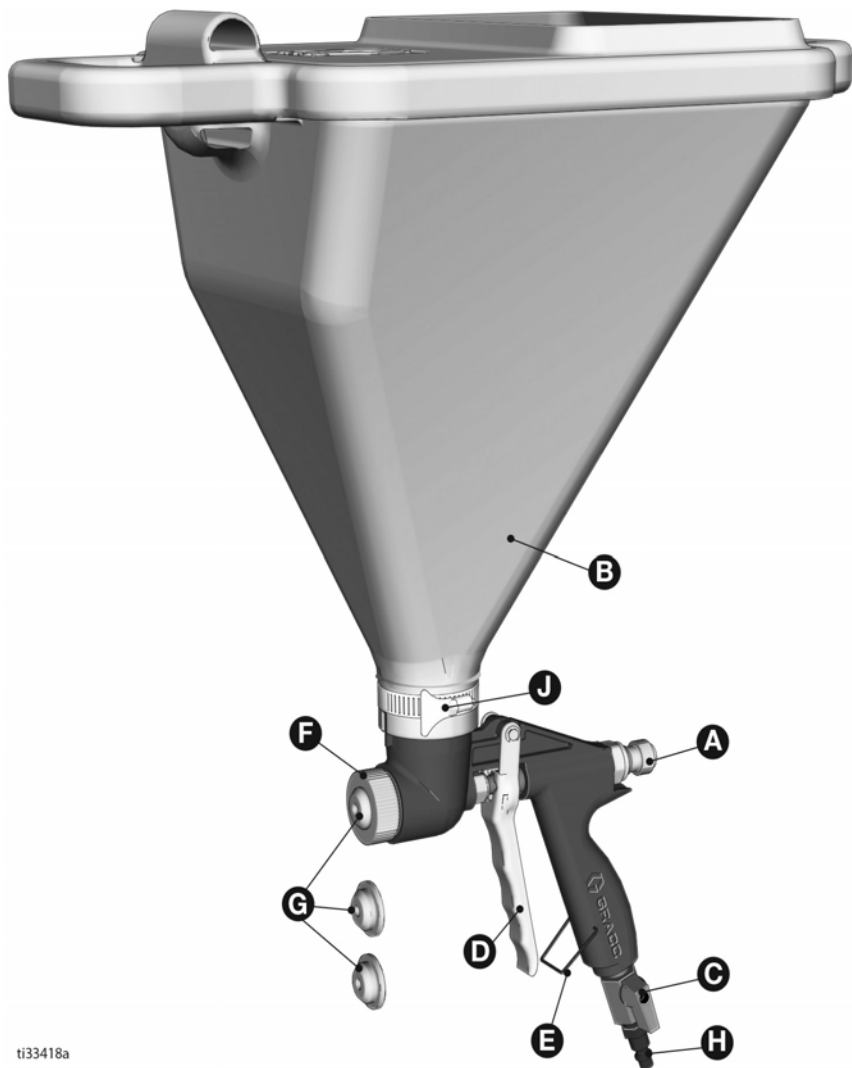

ti33418a

A	Needle Travel Adjustment Knob
B	Hopper
C	Air Valve
D	Trigger
E	Trigger Lock

F	Nozzle Retainer
G	Material Nozzles (4mm, 6mm & 8mm)
H	Air Hose Fitting
J	Hopper Clamp

Component Identification

25D490 - Air Compressor

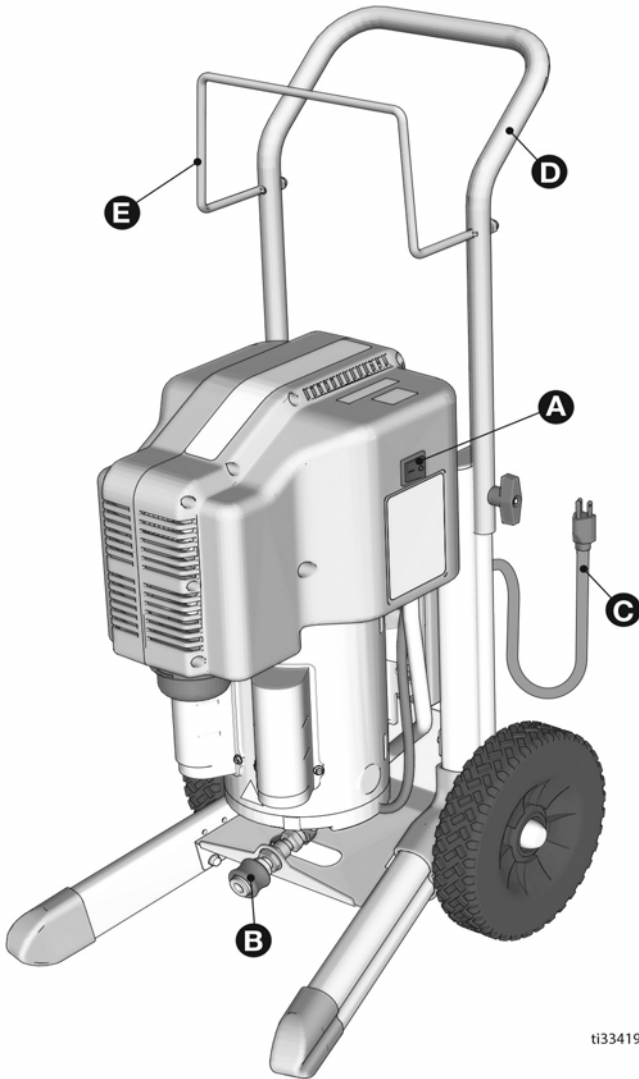

A	Power Switch
B	Air Hose Fitting
C	Power Cord

D	Cart Handle
E	Hose/Power Cord Storage

Preparation

Preparation

Pressure Relief Procedure



Follow the Pressure Relief Procedure whenever you see this symbol.



The hopper is pressurized. To reduce the risk of splashing from pressurized fluid, always follow the **Pressure Relief Procedure** before removing the hopper from the gun.

1. Turn air compressor ON/OFF switch to the **OFF** position.

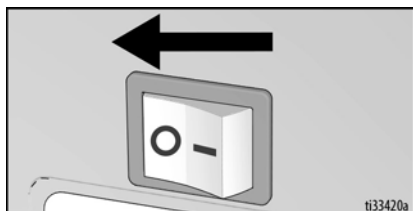

2. Unplug power cord.

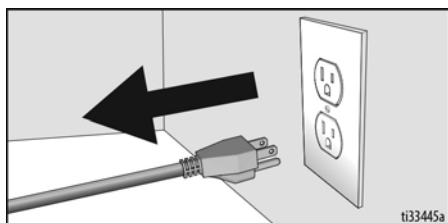

3. Disconnect spray gun from air hose.

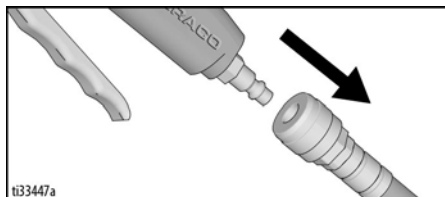

4. Open pressure relief valve on gun by pressing button (pressurized gun only). Aim gun into waste bucket and trigger the gun until all air and material pressure is relieved.

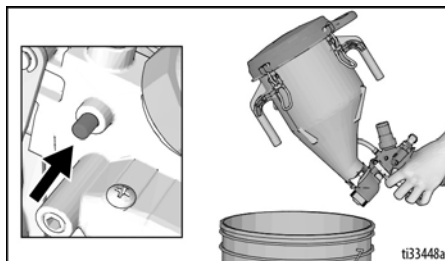

Grounding



The equipment must be grounded to reduce the risk of static sparking and electric shock. An electric or static spark can cause fumes to ignite or explode. An improper ground can cause electric shock. A good ground provides an escape wire for the electric current.

This product is equipped with a cord that has a grounding wire and an appropriate grounding plug. The plug must be plugged into an outlet that is properly installed and grounded in accordance with all local codes and ordinances.

Do not modify the plug provided; if it does not fit the outlet, have the proper outlet installed by a qualified electrician.

Power Supply

For best performance and reliable starting, the air compressor must be plugged into a dedicated circuit, as close as possible to the fusebox or circuit breaker. The compressor will use the full capacity of a typical 15 amp household circuit.

If connected to a circuit protected by fuses, use time-delay fuses with this product.

Extension Cords

NOTE: Avoid use of extension cords if possible.

For optimum performance, plug compressor power cord directly into a grounded wall socket. Do not use an extension cord unless absolute necessary. Instead, use a longer air hose to reach the area where the air is needed.

If an extension cord is necessary, use 12 AWG (2.5 mm²) minimum, 50 feet maximum length.

Setup

Setup

NOTICE

- Do not store spray system under pressure. This may cause damage to the spray system.
- Do not allow material to dry inside hopper, hoses, gun or spray system. This may cause system to fail.

When unpacking spray system for the first time or after long term storage, perform setup procedure.

1. Connect one end of air hose to the compressor air outlet fitting and the other end to the gun air inlet fitting.

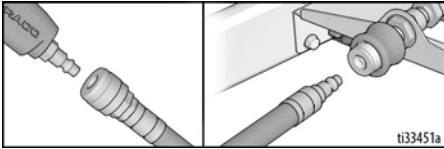

2. Install material nozzle on front of gun and secure using retaining ring. Pulling the trigger when installing nozzle makes assembly easier.

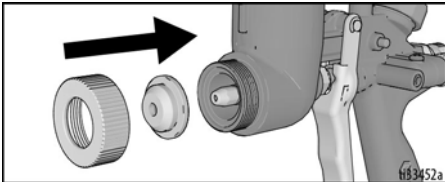

3. Test gun trigger. Lubricate needle seals if necessary.

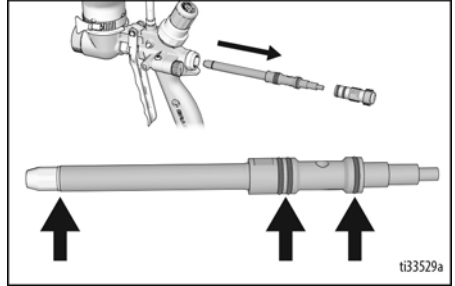

4. Plug power cord into a properly grounded outlet.

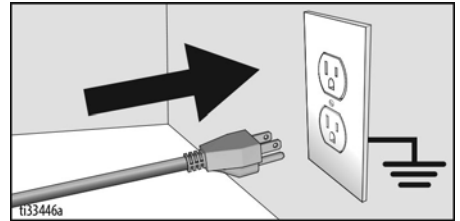

Material Hopper

When spraying ceilings, the hopper should be tilted forward. When spraying floors, the hopper should be tilted backward. Doing so aids in emptying more texture from the hopper.

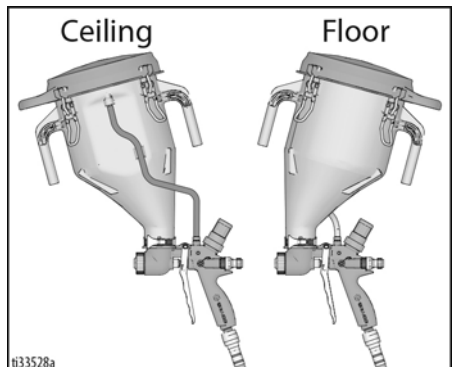

Install Hopper

1. Apply grease to o-ring to make hopper easier to attach to the gun.
2. Loosen hopper clamp, slide it over the rib and toward the top of the hopper.
3. Position hopper outlet over the hopper port on the gun and push hopper down as far as it will go, while slightly rotating.

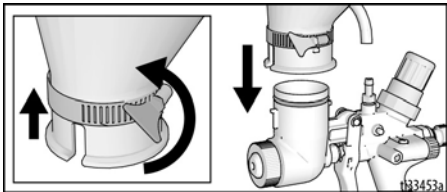

RUPTURE HAZARD				
Over-pressurizing the hopper can result in rupture. To avoid injury, only pressurize hopper by connecting air supply tube to bars on hopper and gun.				

4. Slide down hopper clamp. Hand tighten the clamp.

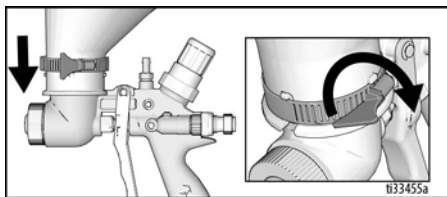

5. **Pressurized hopper gun only:** Attach tube from hopper barb to gun barb.

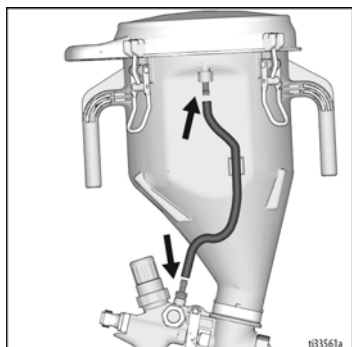

6. **Pressurized hopper gun only:** If lid is too loose and leaks air when pressurized, adjust the four lid clamps to tighten lid.

NOTE: Pre-tighten all four lid clamps approximately 75% of the way, then fully tighten two opposite clamps at once before tightening the other two clamps. The lid should be tightened evenly on the hopper.

NOTICE

Over-tightening the lid may damage the hopper and/or hopper lid.

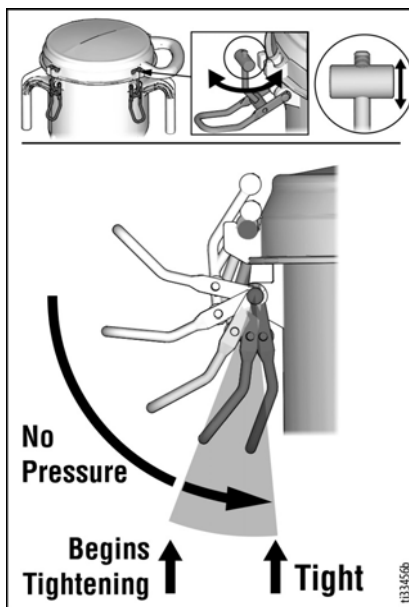

Setup

Remove Hopper

1. Loosen hopper clamp. Hopper clamp is hand-tightened and should not require tools to loosen.
2. Lift hopper straight up, off the hopper port on the gun.
3. **Pressurized hopper gun only:**
Remove tube from barb.

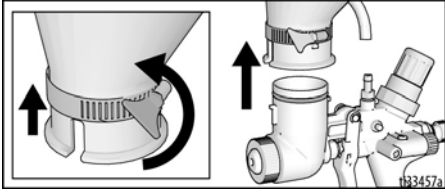

Mixing Material



- Mix the material in a separate container before pouring it into hopper.
- If thicker materials are desired, test material flow in hopper first. Then spray a test pattern.
- For best results, do not use partial bags of material.

1. Mix the material and water in a separate container.

Dry Mix

Carefully mix texture material and water according to manufacturer instructions on bag.

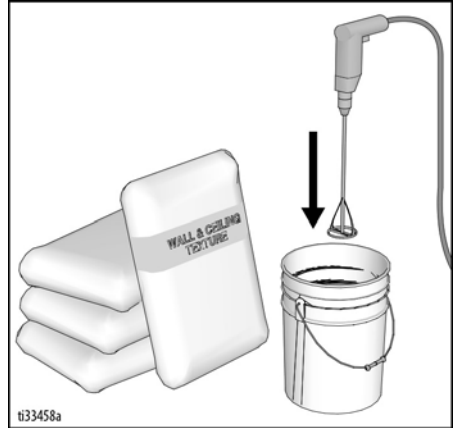

Premix

- Slowly add approximately 2 to 4 quarts (1.9 to 3.8 liters) of water to a 5 gallon (18.9 liter) bucket of premix.
2. Agitate to mix, using a half-inch, variable speed drill with mixing paddle, to a smooth, lump-free consistency.
 3. Allow ceiling texture to set for at least 15 minutes. Then remix prior to use.

Operation (Pressurized Hopper Gun)

Operation (Pressurized Hopper Gun)

For the best spraying experience, always follow the Setup and Operation procedures. This ensures that the material and spray system are ready to spray resulting in a successful project.



Texture Spraying

1. Install material nozzle.

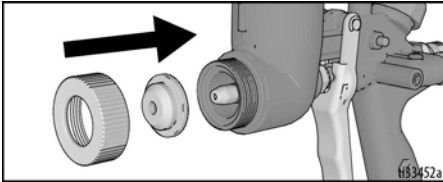

2. Fill hopper with prepared texture material. See **Mixing Material**, page 14.

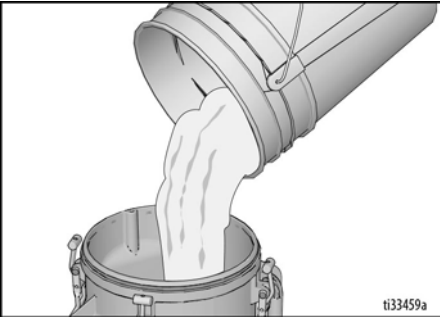

3. Fasten lid.

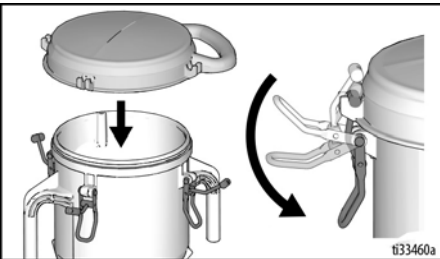

4. Turn air compressor power switch ON. Adjust air flow valve and material flow regulator on hopper gun for desired texture.

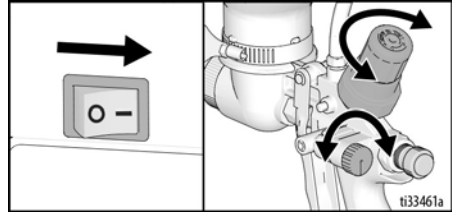

NOTICE

If material gets in needle or gun air passages, flush with water immediately.

5. For proper spray pattern and gun adjustments, see **Adjusting the System (Pressurized Gun Only)**, page 16.
6. To achieve uniform spray pattern, adjust air flow valve, needle travel and material flow regulator. If you do not achieve the desired pattern, change nozzles.

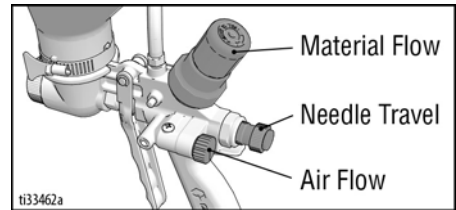

Operation (Pressurized Hopper Gun)

Adjusting the System (Pressurized Gun Only)

Sufficient fluid output (volume and pressure) and good atomization is a balance of atomizing air, material thickness/material flow and nozzle selection. Achieving the correct balance for your application requires experimentation to achieve desired results. Keep in mind these important points when adjusting gun:

- To select correct nozzle for your applications, consider size of aggregate in material and coarseness of spray pattern. Remember the larger the material nozzle, the larger the pattern.

Application	Nozzle Size ¹	Air Volume ²
Simulated Acoustic	6 mm (<i>fine to medium</i>) 8 mm (<i>coarse</i>)	Medium to High
Orange Peel	4 mm 6 mm	Medium to High
Splatter Coat	6 mm 8 mm	Low to Medium
Knock down	8 mm	Low

¹ For more material volume, try a larger nozzle.
² Adjust air volume with gun air flow valve.

- Set material flow by closing air flow valve, and adjusting material flow regulator, while pulling trigger to get the appropriate material flow.
- Start spray system with air flow valve completely open. If needed, slowly close gun air flow valve until you get the desired spray pattern. Use minimum amount of air at spray gun to achieve proper spray pattern and to minimize bounce back.

+ Test spray pattern on cardboard. Hold gun 18 to 48 in. (45.7 to 122 cm) from surface. Use this spraying distance for most applications.

+ When spraying with a material nozzle only, overlap each stroke 50% in a circular motion.

+ When spraying with a material nozzle and disc, overlap each stroke 50% in a linear motion.

- Gun air flow is regulated using air flow valve located on the left side of the gun.

+ Opening air flow valve (counterclockwise) increases air flow through gun.

+ Closing air flow valve (clockwise) decreases air flow through gun.

For Less Material Flow

Try one or a combination of these methods:

- Turn material flow regulator knob counter-clockwise on gun to decrease material flow.
- Use thicker material mixture.
- Use smaller material nozzle.
- Increase needle travel.

For More Material Flow

Try any one or a combination of these methods:

- Turn material flow regulator knob clockwise on gun to increase material flow.
- Use thinner material mixture.
- Use a larger material nozzle.
- Decrease needle travel.

For Continuous Spraying

Use trigger lock to hold trigger open and reduce fatigue (only on gravity-fed gun)

Check Material Consistency Periodically

Check and thin material as needed to maintain proper consistency. The material may thicken as it sits and slow down production. Agitate periodically.

Cleanup



Once you finish spraying, follow these steps to clean your gun and hopper.

1. Perform **Pressure Relief Procedure**, page 10.
2. Drain remaining material into a bucket until most of the texture material is out of hopper.



ti33463a

3. Fill hopper with clean water.



ti33464a

4. Remove nozzle from gun. Trigger gun into bucket until most of texture mix is out of the hopper. Allow water to flow through gun until gun is clean.

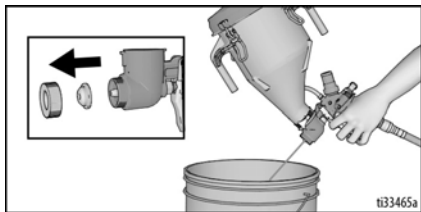

ti33465a

5. Open gun air flow valve, allowing air through nozzle to clear out any remaining material.

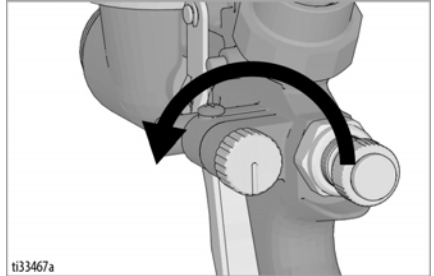

ti33467a

6. Disconnect spray gun from air hose.

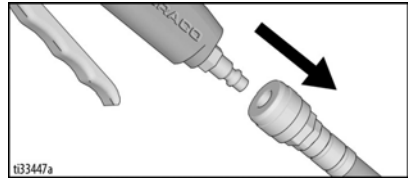

ti33447a

7. Remove hopper from gun and finish cleaning all components. A soft brush may be used to help loosen any dried material from the surface.

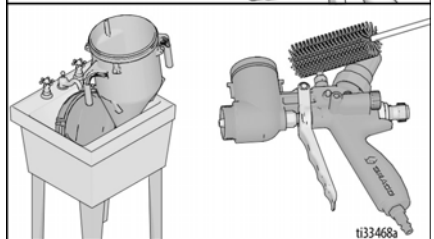
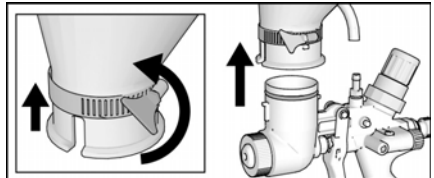

ti33468a

8. Connect air hose to gun.
9. Turn air compressor ON.
10. Open gun air flow valve to allow air flow through the needle to clear out remaining material. Perform **Pressure Relief Procedure**, page 10.
11. If trigger feels sticky, lubricate needle seals.

Troubleshooting



Problem	Cause	Solution
Motor stops	Muffler plugged	Clean filter.
	Motor overheated	Wait X minutes and restart compressor.
	Tripped circuit breaker	Check extension cord length, see Extension Cords , page 11.
Make sure vents are not restricted on motor cover.		
No (or too little) air flow	Solenoid air relief	Replace solenoid.
No (or too little) material flow	No pressure in hopper	Make sure hopper tube is attached.
	Material flow regulator knob adjusted too low	Turn material flow regulator knob clockwise to increase flow, see For More Material Flow , page 16.
	Air compressor is turned OFF	Turn air compressor ON, see Operation (Pressurized Hopper Gun) , page 15.
	Hopper lid too loose (leaks air)	Tighten hopper lid. See step 5, page 13.
	Hopper air passageway and/or hopper tube is plugged	Clear air passageway and/or hopper tube of debris.
	Material nozzle is clogged	Clear nozzle of debris.
	Hopper is empty	Fill hopper with prepared texture material. See Mixing Material , page 14.
Too much material flow	Material texture too thin	Mix texture with less water.
	Material nozzle too big	Switch to smaller material nozzle size.
	Material flow regulator knob adjusted too high	Turn material flow regulator knob counterclockwise to decrease flow, see For Less Material Flow , page 16.
Texture sprayed is too fine	Too much air flow	Turn air flow valve counterclockwise to decrease air flow.
	Material nozzle too small	Switch to bigger material nozzle size.
	Material flow regulator knob adjusted too low	Turn material flow regulator knob clockwise to increase flow, see For More Material Flow , page 16.

Problem	Cause	Solution
Texture sprayed is too coarse	Too little air flow	Turn air flow valve clockwise to increase air flow.
	Material nozzle too big	Switch to smaller nozzle size.
	Material flow regulator knob adjusted too high	Turn material flow regulator knob counterclockwise to decrease flow, see For Less Material Flow , page 16.
Texture leaking between hopper and gun	Hopper not fully secure to the gun	Push hopper down as far as it will go. See step 3, page 13.
	Hopper clamp loose	Tighten hopper clamp. See step 4, page 13.
	O-ring damaged	Replace o-ring.
	Hopper damaged	Replace hopper.
Gun trigger is sticky		Lubricate trigger.

Parts - Air Compressor

Parts - Air Compressor

25D490 (120V) & 25D491 (230V)

Ref.	Torque
 1	15-20 in-lb (1.7 - 2.3 N•m)
 2	35-40 in-lb (4.0 - 4.5 N•m)

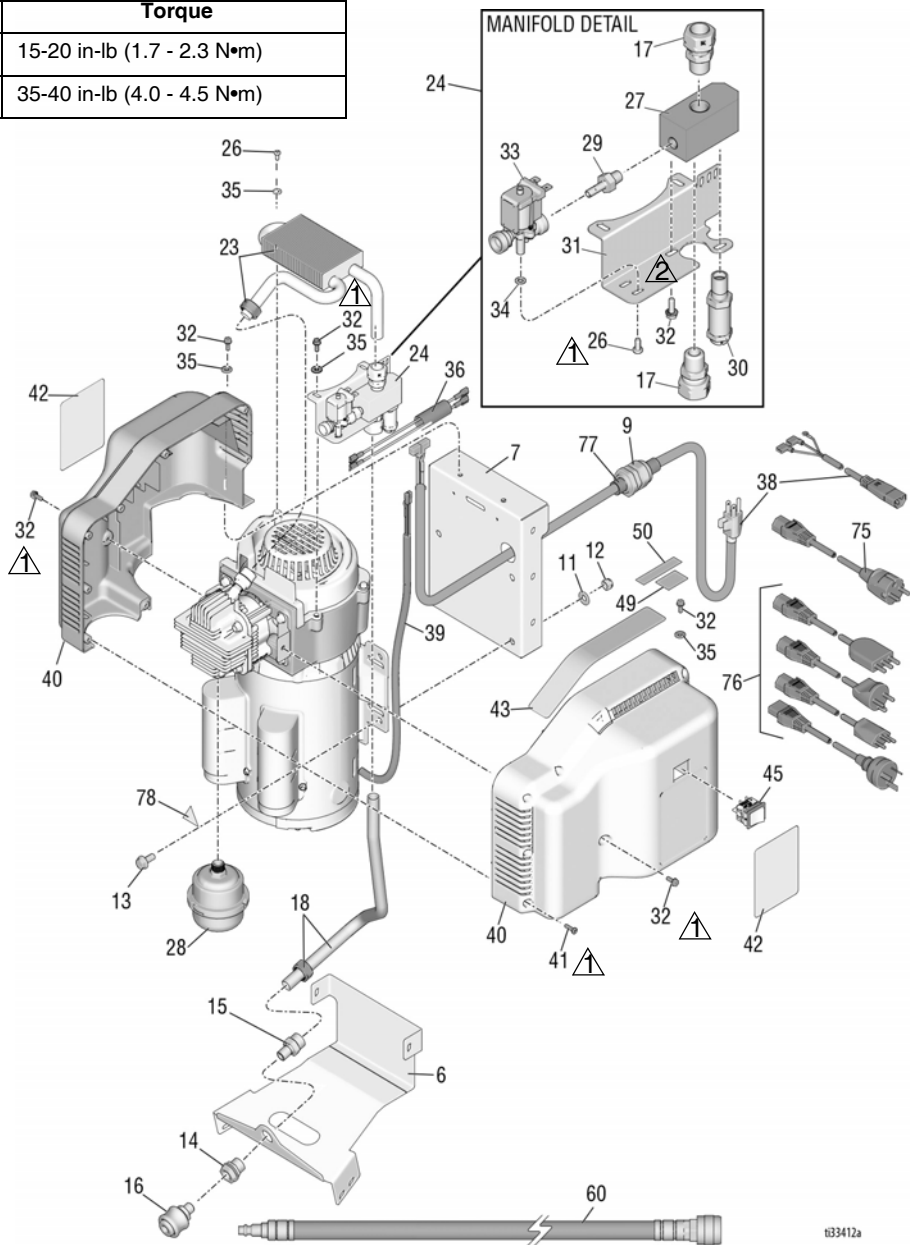

183412a

Parts List - Air Compressor

25D490 (120V) & 25D491 (230V)

Ref.Part	Description	Qty	Ref.Part	Description	Qty
6	17V066 BRACKET, cart, air compressor	1	130485	SOLENOID, 230V	1
7	17V065 PLATE, mounting, motor	1	34	107584 WASHER, plain	2
9	116171 BUSHING, strain relief	1	35	112776 WASHER, plain	5
11	196001 WASHER	4	36	17V678 WIRE, harness, solenoid	1
12	111040 NUT, lock, insert, nylock, 5/16	4	38	17V687 CORD, power, 120V	1
13	110963 SCREW, cap, flange head	4		17U845 CORD, power, 230V	1
14	104641 FITTING, bulkhead	1	39	17V725 HARNESS, wire, motor	1
15	17V716 FITTING, adapter	1	40	26A562 CLAMSHELL, assy.	1
16	17W199 COUPLER, w/ grip	1	41	115477 SCREW, mach, torx pan hd	8
17	130466 FITTING, connector, 5/8 tube	2	42	17V262 LABEL, brand, FastFinish, side	2
18	26A566 TUBE, outlet, manifold	1	43	17V263 LABEL, brand, FastFinish, top	1
23	26A565 KIT, repair, cooler	1	45	17V589 SWITCH, power	1
24	25N024 KIT, manifold, 120V	1	49	16D576 LABEL, made in USA	1
	25N025 KIT, manifold, 230V	1	50	17P924 LABEL, A+ Service, 120V	1
26	15T790 FASTENER, 8-16 plastite .375 lg.	3		17P925 LABEL, A+ Service, 230V	1
27	17U999 MANIFOLD, pneumatic	1	60	26A563 KIT, repair, air hose	1
28	130644 MUFFLER, intake, compressor	1	75	242001 CORD SET, adapter, 230V	1
29	130496 FITTING, adapter	1	76	243280 CORD SET, adapter, 230V	1
30	120617 VALVE, pressure relief	1	77	15F480 SLEEVE, cord, 230V	1
31	17V027 BRACKET, mounting, manifold	1	78▲	15K616 LABEL, caution, hot surface	1
32	16M007 SCREW, mach, serrated hex hd	8			
33	130484 SOLENOID, 120V	1			

▲ Replacement Danger and Warning labels, tags, and cards are available at no cost.

Parts - Air Compressor (cont.)

Parts - Air Compressor (cont.)

25D490 (120V) & 25D491 (230V)

Ref.	Torque
 3	45-55 in-lb (5.1 - 6.2 N•m)

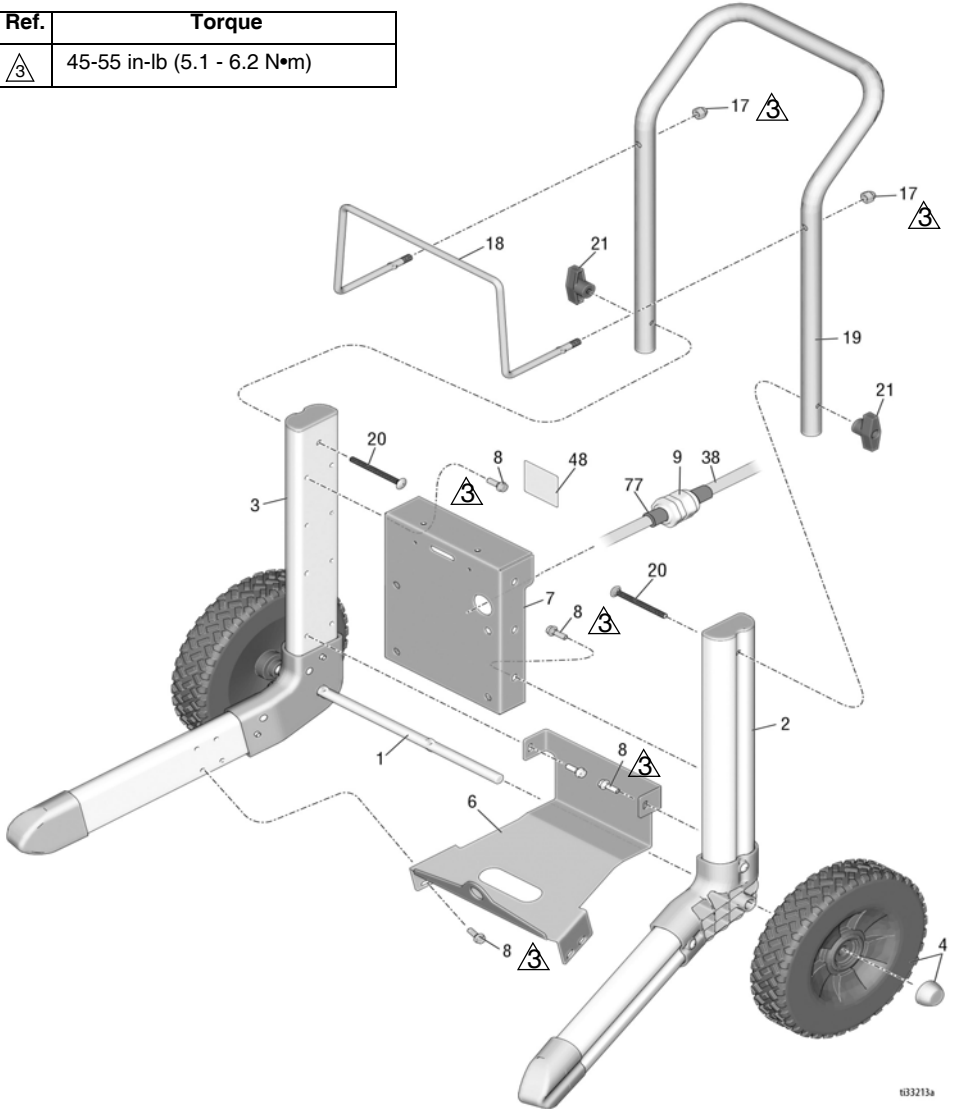

n33213a

Parts List - Air Compressor (cont.)

Parts List - Air Compressor (cont.)

25D490 (120V) & 25D491 (230V)





Ref. Part	Description	Qty	Ref. Part	Description	Qty
1	15R602 AXLE, cart	1	20	120788 SCREW, carriage	2
2	25D526 LEG, cart, left	1	21	115480 KNOB, t-handle	2
3	25D527 LEG, cart, right	1	38	17V687 CORD, power, 120V	1
4	24Y324 KIT, repair, wheel & hub cap	2		17U845 CORD, power, 230V	1
6	17V066 BRACKET, cart, air compressor	1	48▲	17V950 LABEL, warning, electric shock, 120V	1
7	17V065 PLATE, mounting, motor	1		▲ 17W875 LABEL, warning, electric shock, 230V	1
8	260212 SCREW, hex washer hd, thd form	12			
9	116171 BUSHING, strain relief	1			
17	120689 NUT, hex	2			
18	16H350 RACK, hose	1			
19	16H353 HANDLE, cart	1			

▲ Replacement Danger and Warning labels, tags, and cards are available at no cost.

Parts - Air Compressor

Parts - Air Compressor

25D490 (120V) & 25D491 (230V)

Ref.	Torque
 1	215-225 in-lb (24.3 - 25.4 N•m)
 2	115-125 in-lb (13.0 - 13.1 N•m)
 3	15-20 in-lb (1.7 - 2.3 N•m)
 4	120-140 in-lb (13.6 - 15.9 N•m)
 5	50-65 in-lb (5.6 - 7.3 N•m)

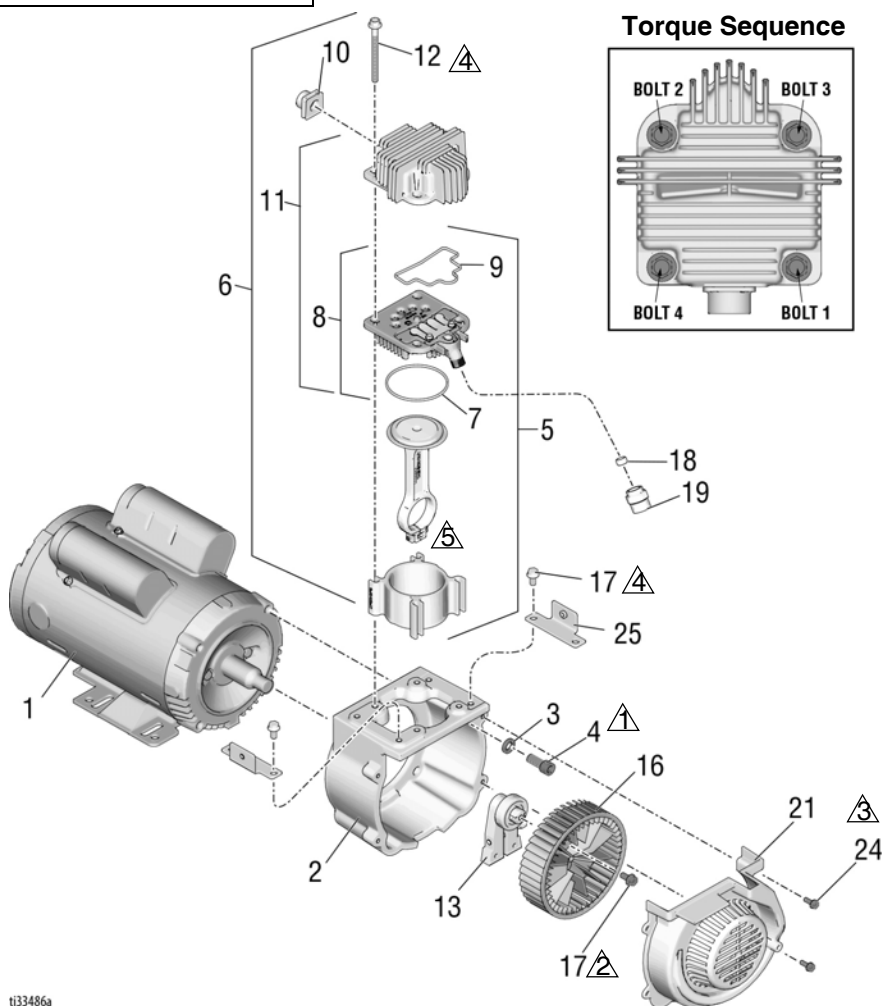

t133486a

Parts List - Air Compressor

25D490 (120V) & 25D491 (230V)

Ref. Part	Description	Qty	Ref. Part	Description	Qty
1	MOTOR, AC, 120V	1	11	24S130 HEAD, compressor	1
	MOTOR, AC, 230V	1	12	17H560 SCREW, cap, serrated flange hd	4
2	17H800 HOUSING, air compressor	1	13	26A561 SHAFT, crank, air	1
3	100133 WASHER, lock, 3/8	4	16	130451 FAN, blower wheel, air cooler	1
4	556517 SCREW, 3/8-16 x .875	4	17	113161 SCREW, flange, hex hd	5
5	24S150 CYLINDER, compressor	1	18	130437 SLEEVE, compression nut, 3/8 tube	1
6	26A560 KIT, repair, compressor	1	19	17U844 FITTING, cylinder head	1
7	17H554 O-RING, square	1	21	17V045 COVER, blower fan, compressor	1
8	24S131 PLATE, valve assembly	1	24	16M007 SCREW, mach, serrated hex hd	2
9	17H555 O-RING, head	1	25	17U929 BRACKET, shroud support	2
10	17V541 ADAPTER, inlet, air compressor	1			

Parts - Pressurized Hopper 25D496

Parts - Pressurized Hopper 25D496

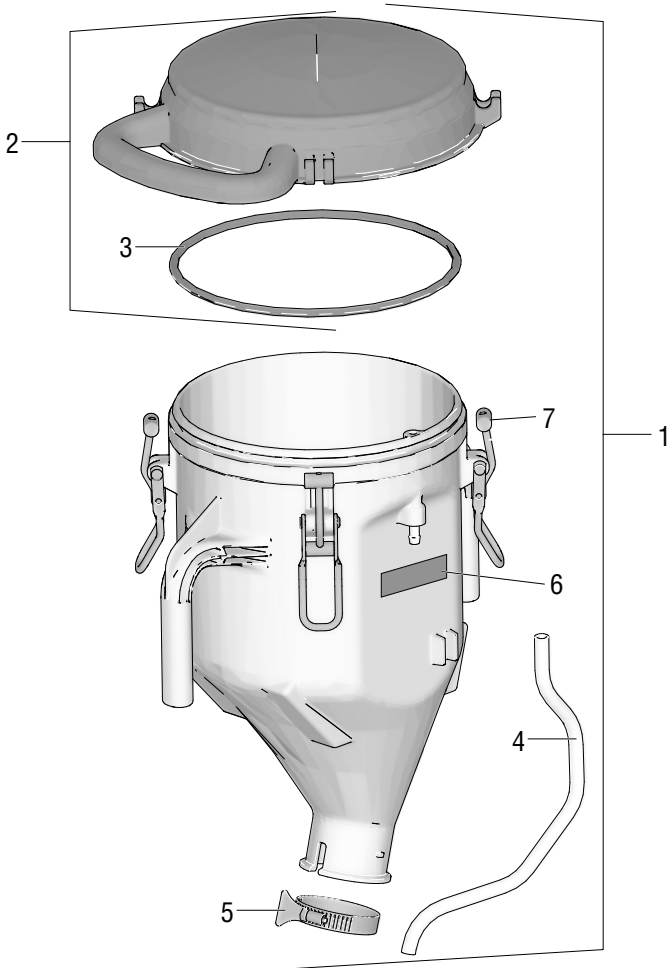

ti33414a

Parts List- Pressurized Hopper 25D496

Parts List- Pressurized Hopper 25D496

Ref.Part	Description	Qty
1	17V946 HOPPER, assembly	1
2	17V947 LID, hopper, pressurized	1
3	17V246 O-RING	1
4	17V945 TUBE	1
5	17V223 CLAMP, hopper	1
6	17W835 LABEL, wpr	1
7	17V709 PIN	4

Parts - Pressurized Gun 25D496

Parts - Pressurized Gun 25D496

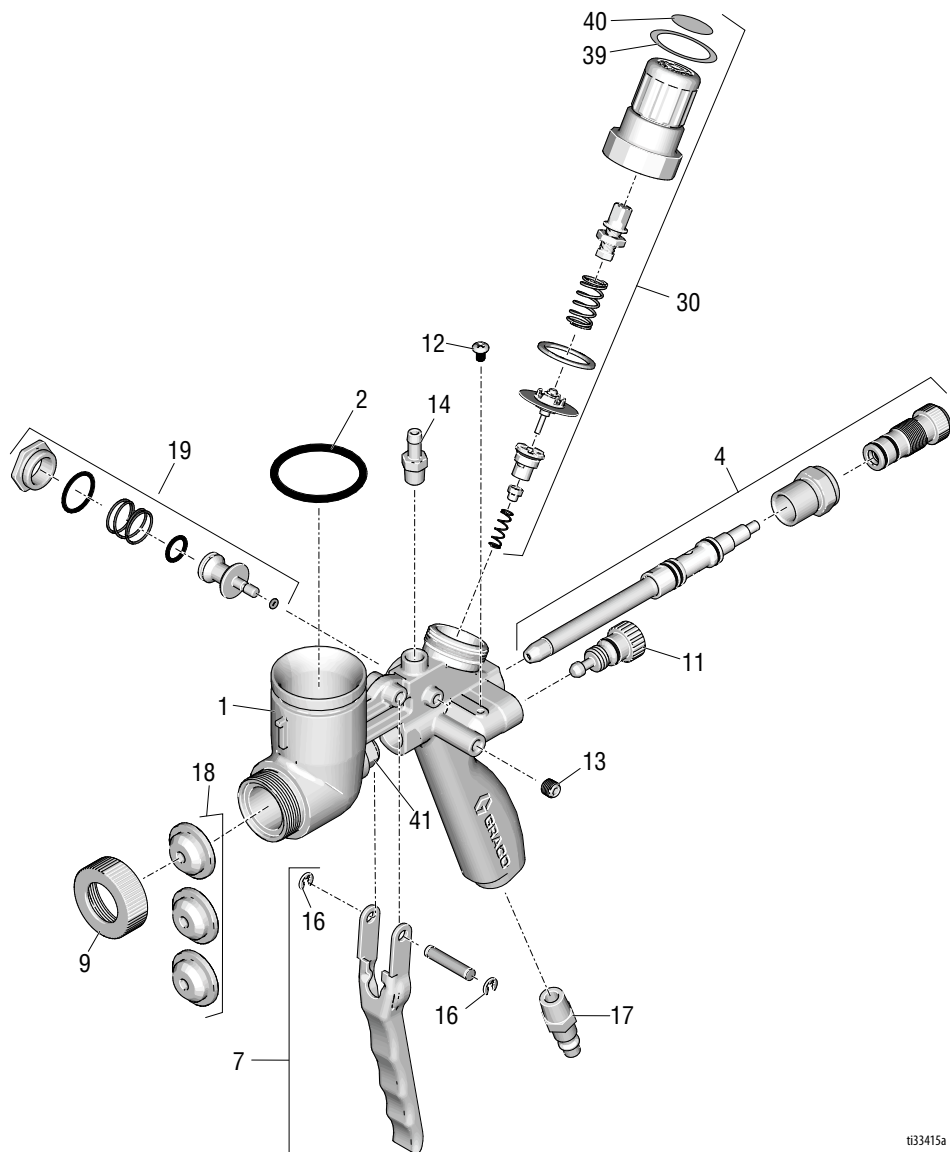

t33415a

Parts List - Pressurized Gun 25D496

Parts List - Pressurized Gun 25D496

Ref.Part	Description	Qty	Ref.Part	Description	Qty
1	GUN, body, pressurized	1	21	SPRING, valve, relief	1
2†	17V705 O-RING	1	22†	O-RING	1
4	17V948 NEEDLE, assembly <i>includes 5, 6, 41</i>	1	23	PISTON, valve, relief	1
5	BUSHING	1	24†	O-RING	1
6	KNOB, adjusting, assy	1	30	17V953 HOUSING, regulator <i>includes 31-40</i>	1
7	17V944 KIT, repair, trigger	1	31	ADJUSTER, regulator	1
9	17U921 CAP, retaining	1	32	SPRING, adjusting, regulator	1
11	17V980 KIT, repair, valve	1	33	RING, retainer, regulator	1
12	17V711 SCREW, 8-32 UNC	1	34	SPRING, seat, regulator	1
13	17V710 PLUG, 1/16-27 NPT	1	35	SEAT, thread, regulator	1
14	17V192 FITTING, 1/8-27 NPT	1	36	HOLDER, diaphragm, assy.	1
16	131180 RETAINING, ring, 4mm	1	37†	PACKING, o-ring	1
17	119394 FITTING, line, air	1	38	PLUG, sealing, regulator	1
18	17V694 KIT, nozzles (4mm, 6mm, 8mm)	1	39	17V664 LABEL, bonnet, regulator	1
19	17V952 KIT, repair, air relief valve <i>includes 20-24</i>	1	40	17V665 LABEL, knob, regulator	1
20†	O-RING	1	† <i>Included in Repair Kit 17V951</i>		

Parts - Gravity-Fed Hopper Gun 25D497

Parts - Gravity-Fed Hopper Gun 25D497

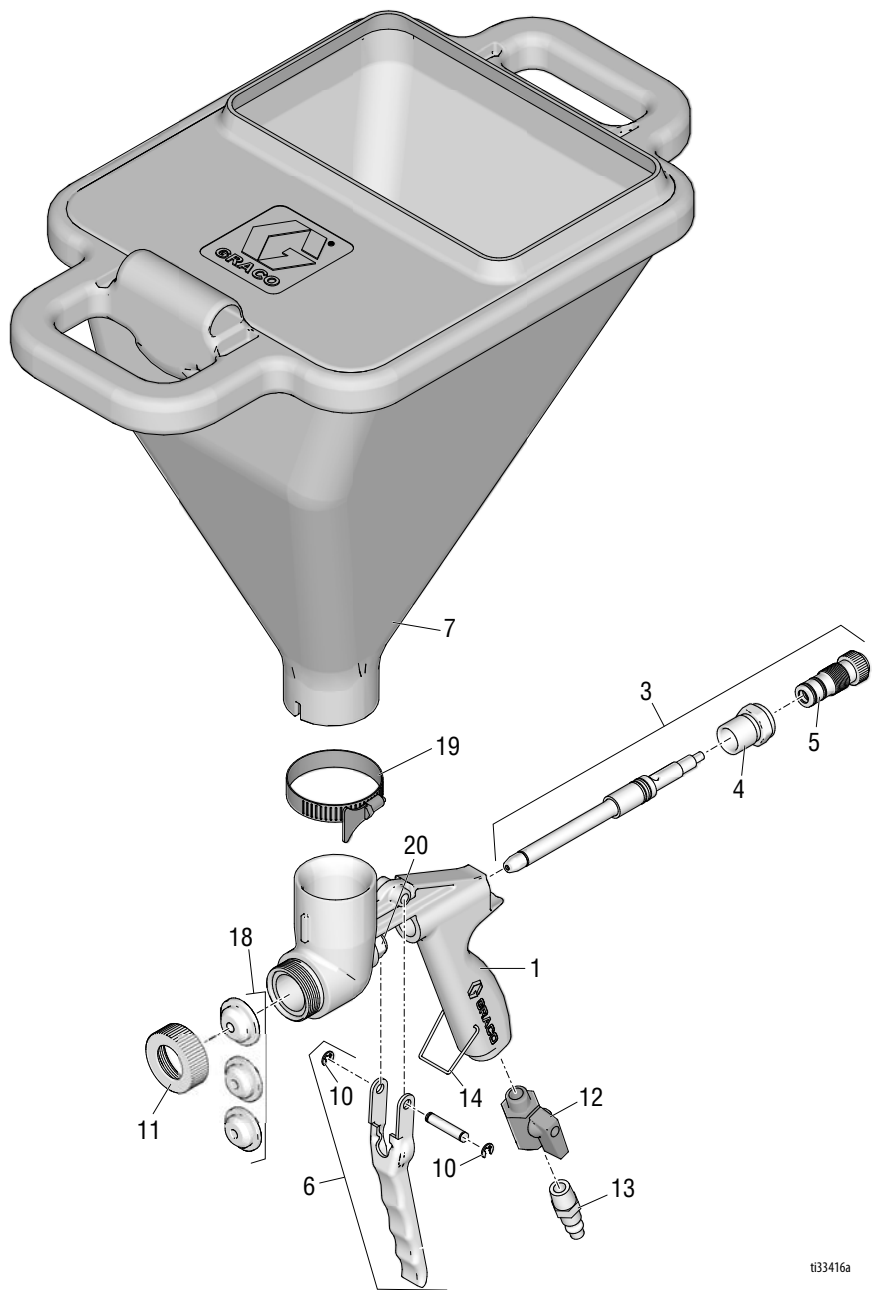

ti33416a

Parts List - Gravity-Fed Hopper Gun 25D497

Parts List - Gravity-Fed Hopper Gun 25D497

Ref. Part	Description	Qty
1	GUN, body, gravity-fed	1
3	17V949 KIT, repair, needle <i>includes 4, 5, 20</i>	1
4	BUSHING	1
5	KNOB, adjusting, assy	1
6	17V944 KIT, trigger, gun	1
7	276873 HOPPER, 1.5 gallon	1
9	PIN, dowel, trigger	2
10	131180 RING, retainer	1
11	17U921 CAP, retaining	1
12	15B565 VALVE, ball	1
13	119394 FITTING, line, air	1
14	17V042 LOCK, trigger	1
18	17V694 KIT, nozzles (4mm, 6mm, 8mm)	1
19	17V223 CLAMP, hopper	1
	17V954 KIT, o-ring	1

Wiring Diagram

Wiring Diagram

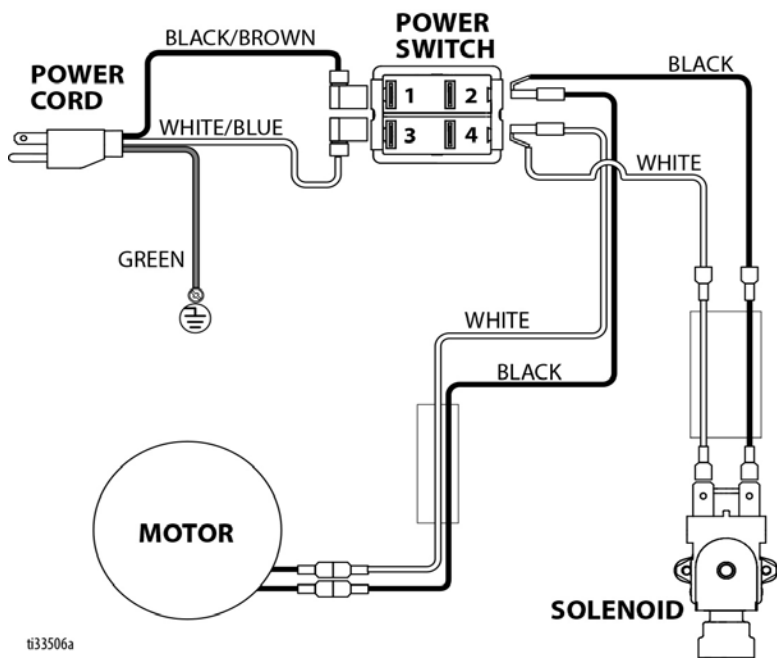

Air Diagram

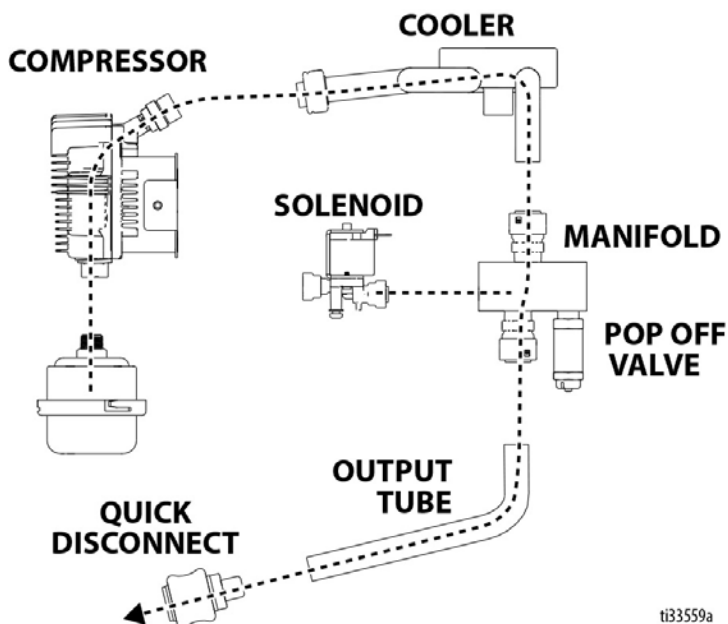

Technical Specifications

Air Compressor & Hopper Guns (Gravity-Fed & Pressurized)		
	US	Metric
Maximum working air pressure		
Pressurized Hopper	5 psi	0.03 MPa, 0.3 bar
Compressor	60 psi	0.41 MPa, 4.1 bar
Pressurized Gun	150 psi	1.03 MPa, 10.3 bar
Air Hose	150 psi	1.03 MPa, 10.3 bar
Noise (dBa)		
Sound Power		
120V	107.1 dBa	
230V	105.7 dBa	
Sound Pressure		
120V	90.2 dBa	
230V	88.8 dBa	
Weight		
Compressor & Hose	73.9 lb.	33.5 kg
Gravity Gun & Hopper	4.3 lb.	2.0 kg
Pressurized Gun & Hopper	5.0 lb.	2.3 kg
Materials of Construction		
Wetted materials on all models	brass, stainless steel, HDPE, aluminum, nitrile, PTFE	
Notes		
<i>*Sound pressure measured 3 feet (1 meter) from equipment. Sound power measured per ISO-3744.</i>		

Graco Standard Warranty

Graco Standard Warranty

Graco warrants all equipment referenced in this document which is manufactured by Graco and bearing its name to be free from defects in material and workmanship on the date of sale to the original purchaser for use. With the exception of any special, extended, or limited warranty published by Graco, Graco will, for a period of twelve months from the date of sale, repair or replace any part of the equipment determined by Graco to be defective. This warranty applies only when the equipment is installed, operated and maintained in accordance with Graco's written recommendations.

This warranty does not cover, and Graco shall not be liable for general wear and tear, or any malfunction, damage or wear caused by faulty installation, misapplication, abrasion, corrosion, inadequate or improper maintenance, negligence, accident, tampering, or substitution of non-Graco component parts. Nor shall Graco be liable for malfunction, damage or wear caused by the incompatibility of Graco equipment with structures, accessories, equipment or materials not supplied by Graco, or the improper design, manufacture, installation, operation or maintenance of structures, accessories, equipment or materials not supplied by Graco.

This warranty is conditioned upon the prepaid return of the equipment claimed to be defective to an authorized Graco distributor for verification of the claimed defect. If the claimed defect is verified, Graco will repair or replace free of charge any defective parts. The equipment will be returned to the original purchaser transportation prepaid. If inspection of the equipment does not disclose any defect in material or workmanship, repairs will be made at a reasonable charge, which charges may include the costs of parts, labor, and transportation.

THIS WARRANTY IS EXCLUSIVE, AND IS IN LIEU OF ANY OTHER WARRANTIES, EXPRESS OR IMPLIED, INCLUDING BUT NOT LIMITED TO WARRANTY OF MERCHANTABILITY OR WARRANTY OF FITNESS FOR A PARTICULAR PURPOSE.

Graco's sole obligation and buyer's sole remedy for any breach of warranty shall be as set forth above. The buyer agrees that no other remedy (including, but not limited to, incidental or consequential damages for lost profits, lost sales, injury to person or property, or any other incidental or consequential loss) shall be available. Any action for breach of warranty must be brought within two (2) years of the date of sale.

GRACO MAKES NO WARRANTY, AND DISCLAIMS ALL IMPLIED WARRANTIES OF MERCHANTABILITY AND FITNESS FOR A PARTICULAR PURPOSE, IN CONNECTION WITH ACCESSORIES, EQUIPMENT, MATERIALS OR COMPONENTS SOLD BUT NOT MANUFACTURED BY GRACO. These items sold, but not manufactured by Graco (such as electric motors, switches, hose, etc.), are subject to the warranty, if any, of their manufacturer. Graco will provide purchaser with reasonable assistance in making any claim for breach of these warranties.

In no event will Graco be liable for indirect, incidental, special or consequential damages resulting from Graco supplying equipment hereunder, or the furnishing, performance, or use of any products or other goods sold hereto, whether due to a breach of contract, breach of warranty, the negligence of Graco, or otherwise.

FOR GRACO CANADA CUSTOMERS

The Parties acknowledge that they have required that the present document, as well as all documents, notices and legal proceedings entered into, given or instituted pursuant hereto or relating directly or indirectly hereto, be drawn up in English. Les parties reconnaissent avoir convenu que la rédaction du présente document sera en Anglais, ainsi que tous documents, avis et procédures judiciaires exécutés, donnés ou intentés, à la suite de ou en rapport, directement ou indirectement, avec les procédures concernées.

Graco Information

For the latest information about Graco products, visit www.graco.com.

For patent information, see www.graco.com/patents.

TO PLACE AN ORDER, contact your Graco distributor or call 1-800-690-2894 to identify the nearest distributor

All written and visual data contained in this document reflects the latest product information available at the time of publication.

Graco reserves the right to make changes at any time without notice.

Original instructions. This manual contains English. MM 3A5725

Graco Headquarters: Minneapolis
International Offices: Belgium, China, Japan, Korea

GRACO INC. AND SUBSIDIARIES • P.O. BOX 1441 • MINNEAPOLIS MN 55440-1441 • USA

Copyright 2018, Graco Inc. All Graco manufacturing locations are registered to ISO 9001.

www.graco.com
Revision A, March 2018